

## Teknisk info "Special vinschar" (220V-410V)

Warn:

Works 3000 ACI

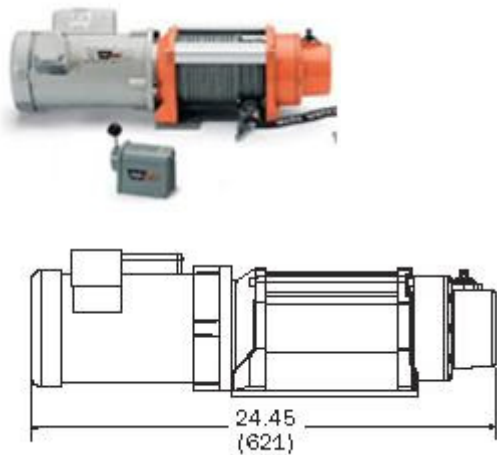

Belastning/ kg	Hastighet (m/min)	Amp.	Drar/la g (kg)
0	3,72	4,6	(1.) 1361
453,6	2,68	5,5	(2.)122 5
680,4	2,68	6,4	(3.) 1116
907	2,62	7,4	(4.)102 1
1134	2,60	8,9	(5.) 939
1361	1,47	10,5	

## Pullzall 230V



Ut/ in funktion

Drar 454 kg

Variabel hastighet

Överbelastningskydd: elektronisk med LED  
lampa

Bröms: dynamisk

Vikt: 6,8 kg

Vajer: 4,57m x 5,5mm

Övriga data: se Pullzall 24V

## Pullzall 24V

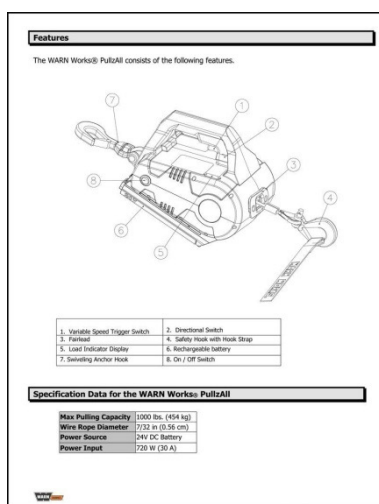

Ut/in funktion

Variabel hastighet

Överbelastningskydd: elektronisk med LED  
lampa

Bröms: dynamisk

Vikt: 8,2kg

Vajer: 4,6m x 6mm

Drag/lyft: 454 kg

Batteri: 24V laddningsbar

Variabel hastighet

Snäckförankringskrok

Indikator för vikt

720W, 30A

Trachtel : (från Interlift):

Minifor

fiche technique  
technical data sheet

minifor™  
TR 10 / TR 30  
Standard / Standard

ref. : I 21/3 F/GB  
rév. n° :  
date : 12/02  
page : 1/1

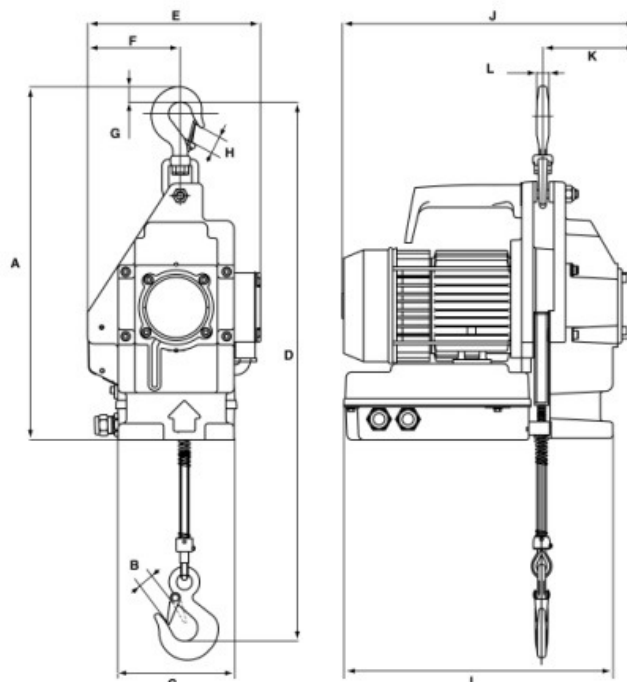

Belastning (kg) TR30S	Hastighet	Vikt	Mått(LxBxH mm)
300kg i enkelt v.	13 m/min	31kg	430x224x492
Vajer 6,5mm		1 fase (230V)	
Fjärrkontroll		Direkte betjäning	
Fjärrkontroll		48V	3 faser (400V)
<b>TR50</b>			
500 i enkelt v.	7	31	430x224x492

Huchez: Tirlev vinsch



- Compact machine with vertical and horizontal mounting
- Max. capacity: 200 kg.
- Max. wire rope capacity: 25 m in 4 mm dia.
- Numerous possibilities for wire rope exit direction by swinging the winch through 90° right or left.

Technical description

- Depending on model: single-phase start capacitor brake motor 220 volts - 50 Hz, or three-phase brake motor 220/380 volts - 50 Hz or 380 volts for 2 speeds.
- Direct control 220 volts single-phase and 220/380 volts three-phase (except 2-speed), with double insulated IP657 control box or 24-volt very low voltage control (option).
- Optional limit-switch system (only with very low voltage control for three-phase models).

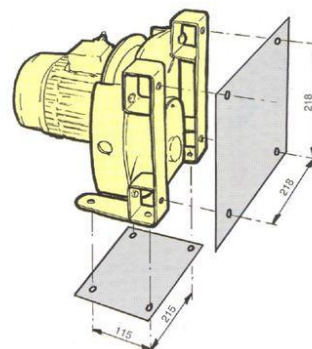

Model	Motor KW	Capacity kg	Speed m/min	Rope capac. m	Rope dia. mm	Weight kg
Tirlev 201 V 20	0,75 mono	200	20	25	4	25
Tirlev 203 V 20	0,75 tri	200	20	25	4	25
Tirlev 203 V 10	0,37 tri	200	10	25	4	25
Tirlev 203 V 12	0,37/0,75 tri	200	10/20	25	4	25

Denna vinsch är mycket kompakt.  
Max vajerlängd: 25m x 4mm.

Där finns många möjligheter att dirigera invischningsvinklan.

Fås som 1-fas (220V)

Fås dom 3-fas(380) med 2 hastigheter.

Fås med direkt kontroll ellar 24V kontroll

Det går att montera begränsning av lyfthöjd men bare för 380V modellen.

Model	Supply	Speed	Direct control	Limit switch	
				24 V LV	24 V LV
Tirlev 201 V 20	Mono	1	•	•	•
Tirlev 203 V 20	Tri	1	•	•	no
Tirlev 203 V 10	Tri	1	•	•	no
Tirlev 203 V 12	Tri	2	no	•	•

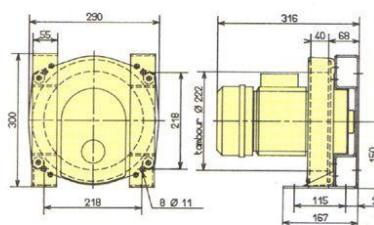

A complete range of lifting equipments

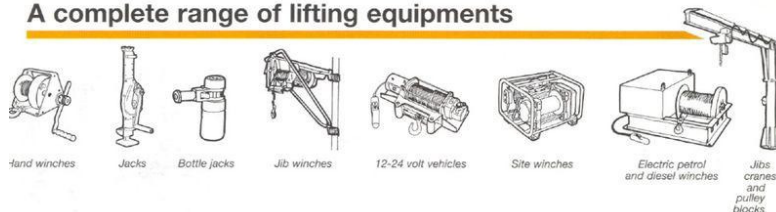

Huchez: TRB vinschar

TRB 250-350 kg:



250 to 350 kg capacity

Fråga LV ([info@laubjerg-import.com](mailto:info@laubjerg-import.com))

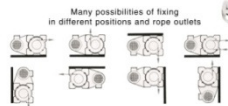

## Dimensions and technical data

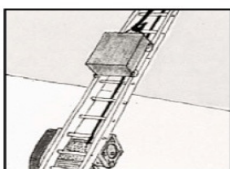

Ladder hoists.

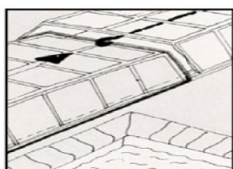

Swimming pool roofs (hauling).

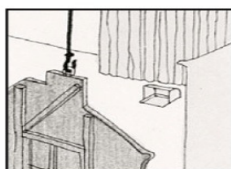

Theatre scenery

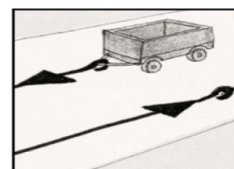

Two-way transport (e.g. of materials and parts to/from machines).

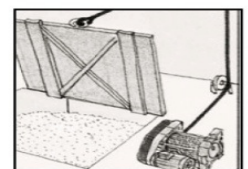

Trap door opening.

TRB: winch designed for maximum functionality and versatility. Available with full voltage or low voltage control.

### TRB 220 V full voltage controlled:

- 240 volts – 50 Hz single-phase or 240-400 volts three-phase self-braking motor – P = 1.1 kW – IP 54 – Start capacitor (for single-phase models)
- Remote control in full voltage: 240 volts S-Ph. or 240/400 volts T-Ph. Protection IP 67. Double insulated.
- Emergency stop.
- Weld steel drum.
- All others technical characteristics same as low-voltage TRB models
- Some optional equipments cannot be fitted on these models, please feel free to contact our sales department.
- The (optional) limit switch device can be installed only on the single-phased models. For the three-phased models, the limit switch will have to be incorporated to the installation. Otherwise a low-voltage model must be selected.

Model	Capacity on the first layer kg	Capacity on the last layer kg	Number of layers	Motor kW	Speed m/min	Rope length m	Rope diameter mm	Weight kg
TRB 251 CD	290	250	3	1.1 S-Ph.	20	60	5	35
TRB 301 CD	345	300	3	1.1 S-Ph.	15	60	5	35
TRB 351 CD	375	350	2	1.1 S-Ph.	15	40	5	35
TRB 353 CD	375	350	2	1.1 T-Ph.	15	40	5	35

The indicated rope diameter corresponds to the capacity on the last layer.

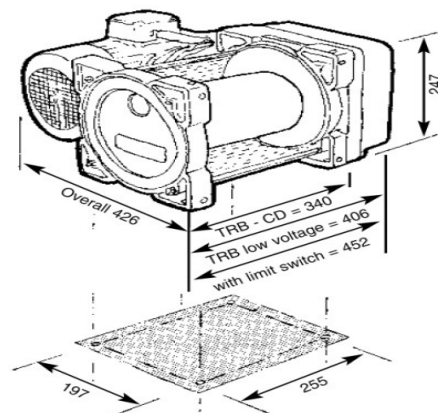

On the 2 mounting planes, the 4 points form a 318 x 246 rectangle (all models).

### TRB low voltage controlled:

- 240 volts – 50 Hz lifting type. Single-phase motor. Start capacitor. Class F. Protection IP 55.
- 240/400 volts – 50 Hz lifting type. Three-phase motor. Class F. Protection IP 55.
- Emergency stop.
- Seal grease-bath helical reduction gearing.
- 24 volts d.c. electromagnetic brake. P = 25 W.
- Weld steel drum.
- Optional 24 volts low voltage control.
- Many optional equipments available.

Model	Capacity on the first layer kg	Capacity on the last layer kg	Number of layers	Motor kW	Speed m/min	Rope length m	Rope diameter mm	Weight kg
TRB 251	290	250	3	1.1 S-Ph.	25	60	5	39
TRB 253	290	250	3	1.1 T-Ph.	25	60	5	39
TRB 301	345	300	3	1.1 S-Ph.	20	60	5	39
TRB 303	345	300	3	1.1 T-Ph.	20	60	5	39
TRB 351	375	350	2	1.1 S-Ph.	15	40	5	39
TRB 353	375	350	2	1.1 T-Ph.	15	40	5	39

The indicated rope diameter corresponds to the capacity on the last layer.

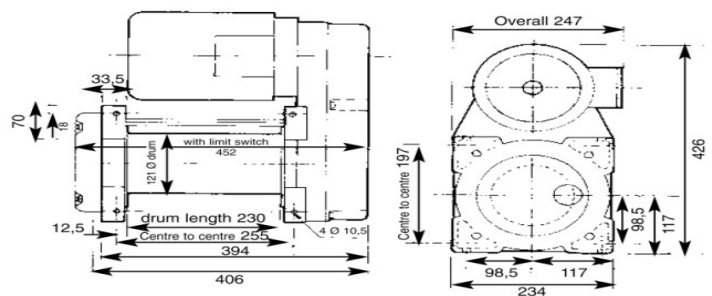

TRB low voltage model

# TRB 500-960 kg



500 to 960 kg capacity

Fråga LV ([info@laubjerg-import.com](mailto:info@laubjerg-import.com))

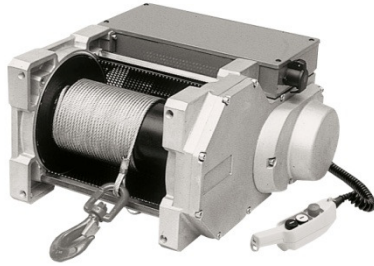

## Dimensions and technical data

**TRB : winch designed for maximum functionality and versatility. Available with full or low voltage control.**

**TRB 220 V full voltage controlled:**

- 240 volts – 50 Hz single-phase or 240-400 volts three-phase self-braking motor – P = 1.1 kW – IP 54 – Start capacitor (for single-phase models)
- Remote control in full voltage: 240 volts S-Ph. or 240/400 volts T-Ph. Protection IP 67. Double insulated.
- Emergency stop.
- Weld steel drum.
- All others technical characteristics same as low-voltage TRB models
- Some optional equipments cannot be fitted on these models, please feel free to contact our sales department.
- The (optional) limit switch device can be installed only on the single-phased models. For the three-phased models, the limit switch will have to be incorporated to the installation. Otherwise a low-voltage model must be selected.

**TRB low voltage controlled:**

- 240 volts – 50 Hz lifting type. Single-phase motor. Start capacitor. Class F. Protection IP 55.
- 240/400 volts – 50 Hz lifting type. Three-phase motor. Class F. Protection IP 55.
- Seal grease-bath helical reduction gearing.
- 24 volts d.c. electromagnetic brake. P = 25 W.
- Weld steel drum.
- Optional 24 volts low voltage control.
- 24 volts remote control with plug.
- Emergency stop.
- Many optional equipments available.

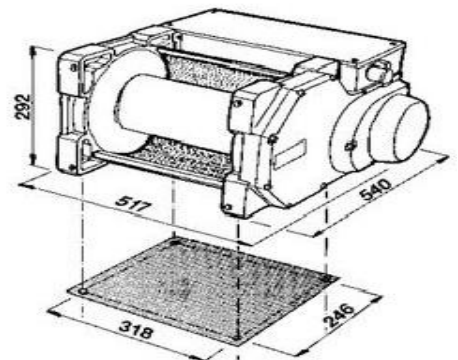

On the 2 mounting planes, the 4 points form a 318 x 246 rectangle (all models).

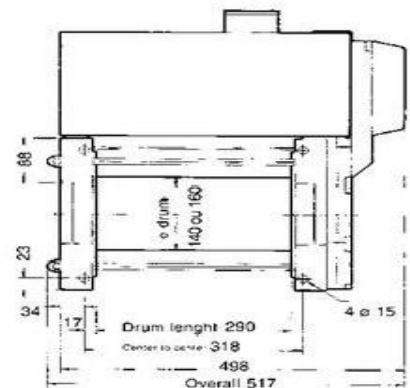
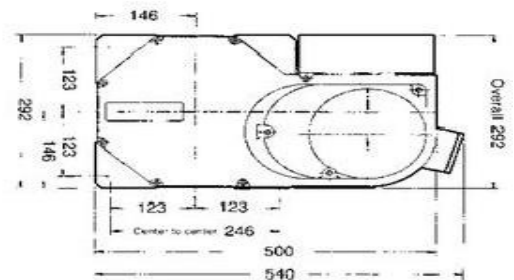

Model	Capacity on the 1st layer kg	Capacity on the last layer kg	Number of layers	Motor kW	Speed m/min	Rope length m	Rope diameter mm	Weight kg
TRB 501 CD	635	500	4	1.5 S-Ph.	9	85	6.8	81
TRB 503 CD	635	500	4	1.1 T-Ph.	5	85	6.8	81
TRB 803 CD	950	800	3	1.1 T-Ph.	5	60	8	81
TRB 963 CD	960	960	1	1.1 T-Ph.	5	17	8	81
TRB 501 - 12	635	500	4	1.5 S-Ph.	12	85	6.8	85
TRB 503 - 5	635	500	4	0.55 T-Ph.	5	85	6.8	85
TRB 503 - 9	635	500	4	1.1 T-Ph.	9	85	6.8	85
TRB 503 - 12	635	500	4	1.5 T-Ph.	12	85	6.8	85
TRB 503 - 18	635	500	4	2.2 T-Ph.	18	85	6.8	85
TRB 503 - 23	635	500	4	3 T-Ph.	23	85	6.8	85
TRB 803 - 5	950	800	3	1.1 T-Ph.	5	60	8	90
TRB 803 - 10	950	800	3	2.2 T-Ph.	10	60	8	90
TRB 803 - 13	950	800	3	2.2 T-Ph.	13	60	8	90
TRB 803 - 17	950	800	3	3 T-Ph.	17	60	8	90
TRB 963 - 5	960	960	1	1.1 T-Ph.	5	17	8	90
TRB 963 - 10	960	960	1	2.2 T-Ph.	10	17	8	90
TRB 963 - 13	960	960	1	2.2 T-Ph.	13	17	8	90
TRB 963 - 17	960	960	1	3 T-Ph.	17	17	8	90
TRC 501 CD	635	500	4	1.5 S-Ph.	9	85	6.8	91
TRC 501 - 12	635	500	4	1.5 S-Ph.	12	85	6.8	95
TRC 503 - 12	635	500	4	1.5 T-Ph.	12	85	6.8	95
TRC 503 - 18	635	500	4	2.2 T-Ph.	18	85	6.8	95
TRC 503 - 23	635	500	4	3 T-Ph.	23	85	6.8	95
TRC 803 - 17	950	800	3	3 T-Ph.	17	60	8	100

The indicated rope diameter corresponds to the capacity on the last layer.

\* ø 140 -> 500 kg  
ø 160 -> 800/960 kg